

# Kan Limfjordstunnelen reddes

"Okay, Houston, we've had a problem here".

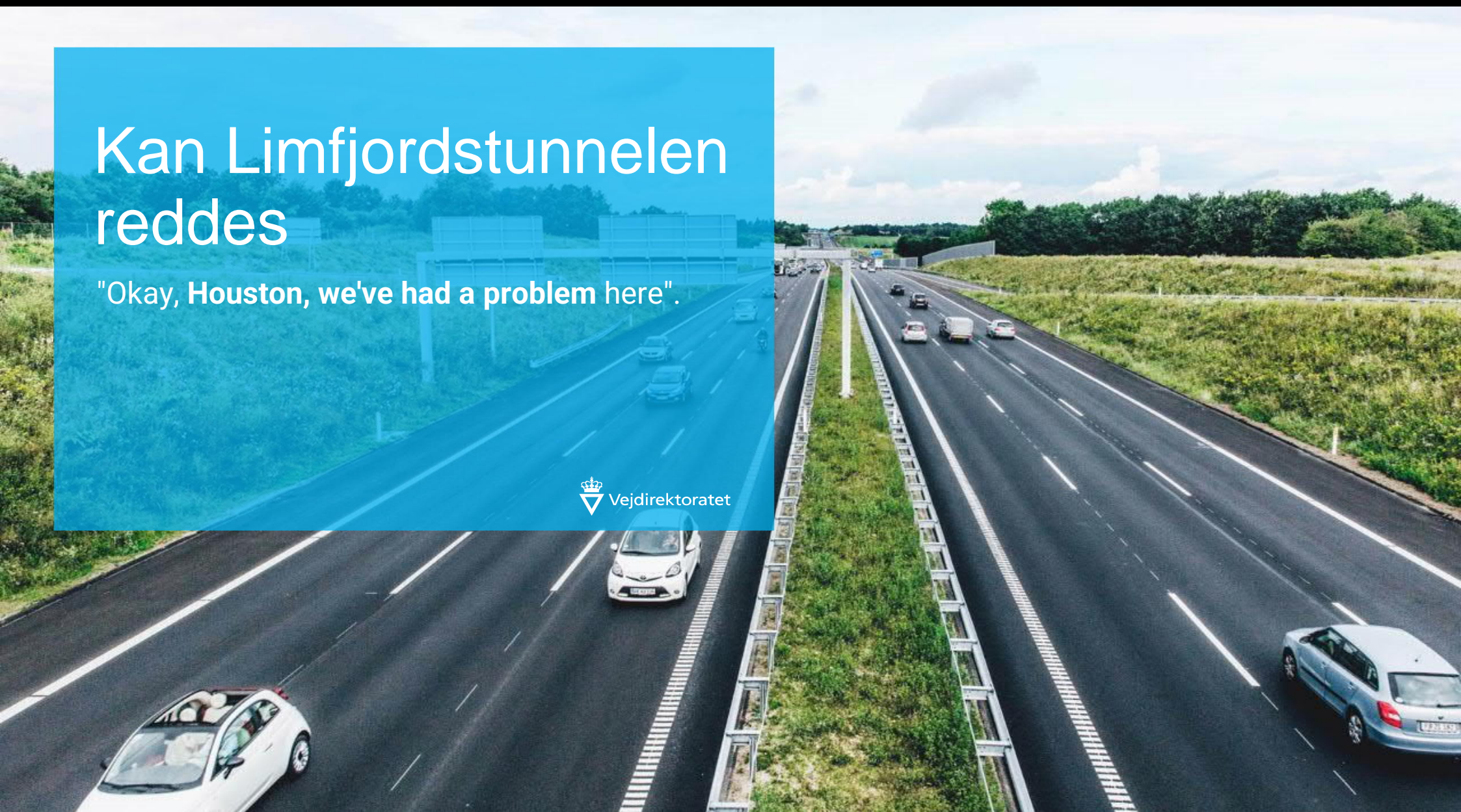

Limfjordstunnelen:

# Kan Limfjordstunnelen reddes?

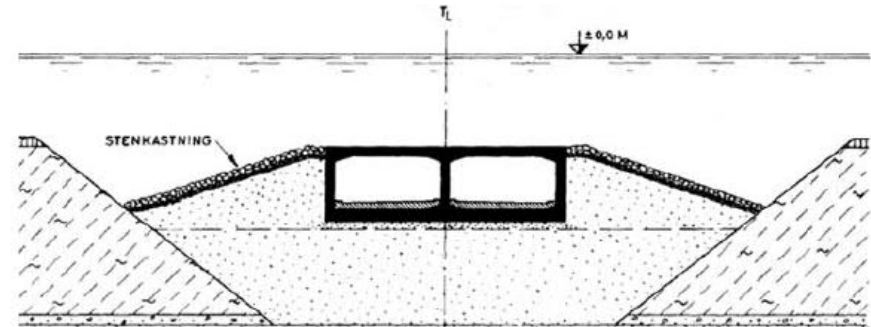
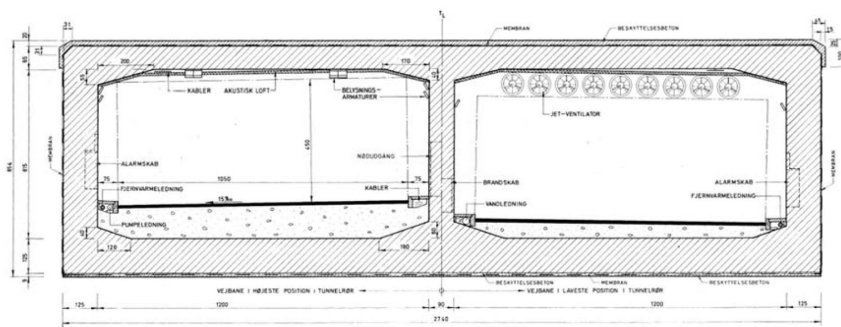
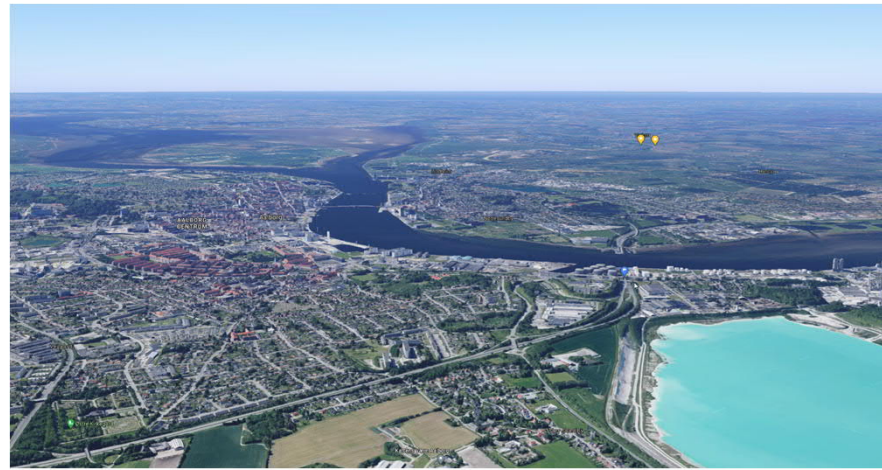

# Trafikmængde – Limfjordstunnelen

## Udvikling i Trafikken

Nedenstående oversigt viser udviklingen i trafikken gennem de sidste 7 år. Der sker et fald i ÅDT i 2020. Årsagen til dette fald kan blandt andet være COVID – 19 pandemien med nedlukning og hjemsendte medarbejdere.

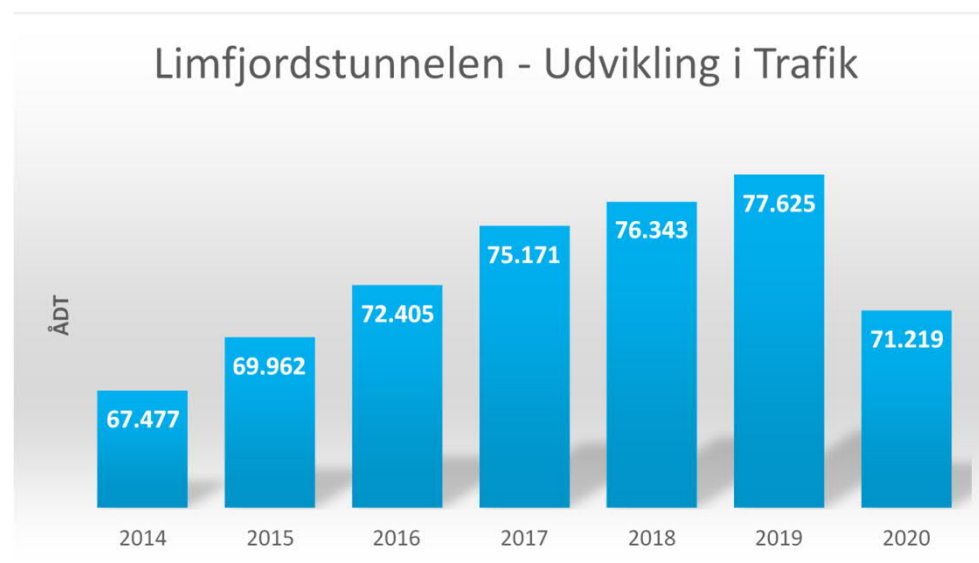

Figur 1, Udvikling i Trafik

## Trafik fordelt over døgnet Limfjordstunnelen 2020

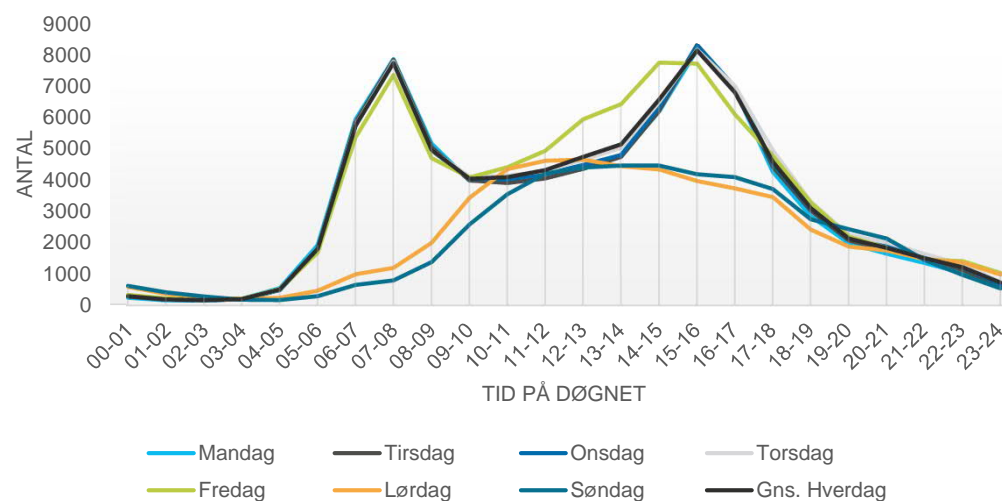

# Konstruktion og opførelse

# Tunnel Description: Structural Layout / Soil Condition

- Typical data

- 5 nos. 102 m long tunnel elements
- ~553m long monolithic structure
- Articulation at each portal structure

- Foundation

- South (TE1, TE2): Sand bedding on top of glacial deposit
- Center -> North (TE3, TE4, TE5): Sand bedding plus Sandfill on top of glacial deposit
- North Portal and Ramps: Concrete piles

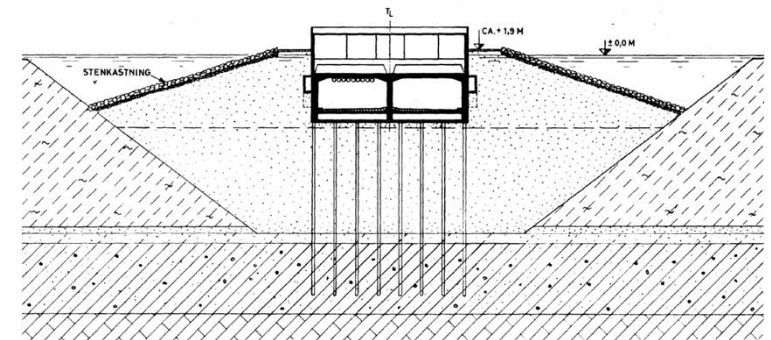
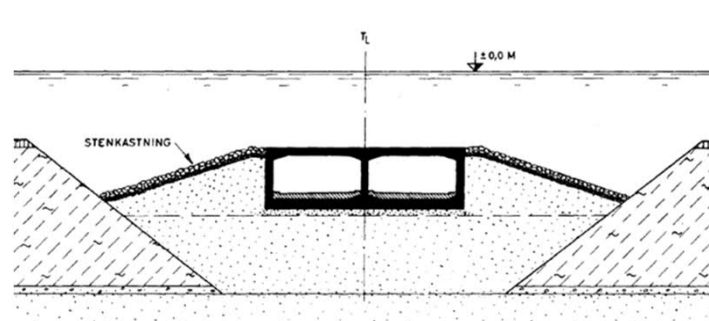
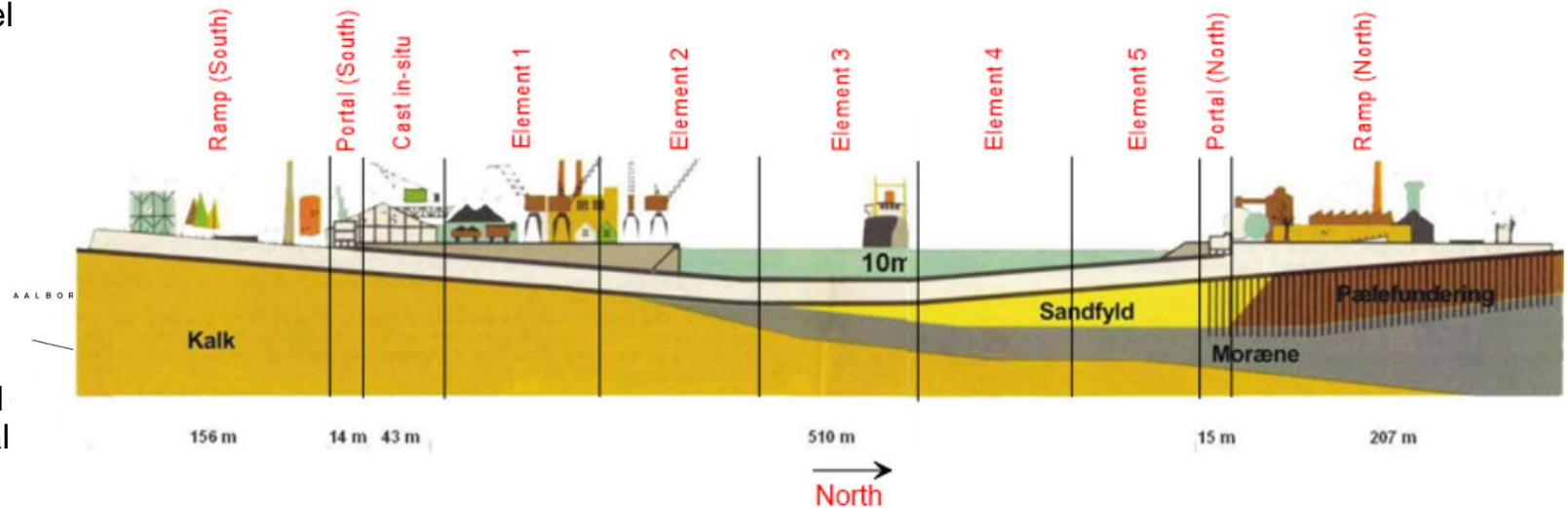

# Tunnel Description: Construction Method

- Foundation
  - Sand fill replacing Gytja
- Tunnel Element
  - 1.8 m infill concrete

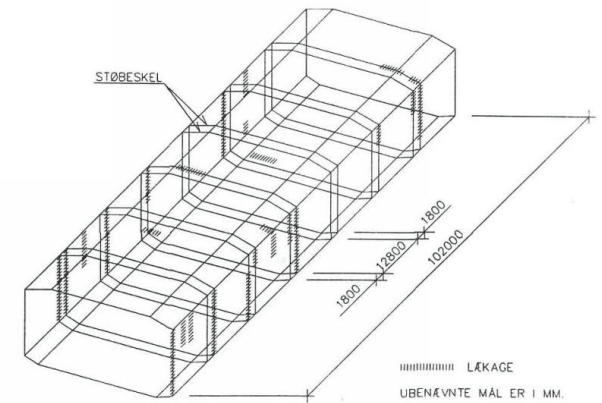
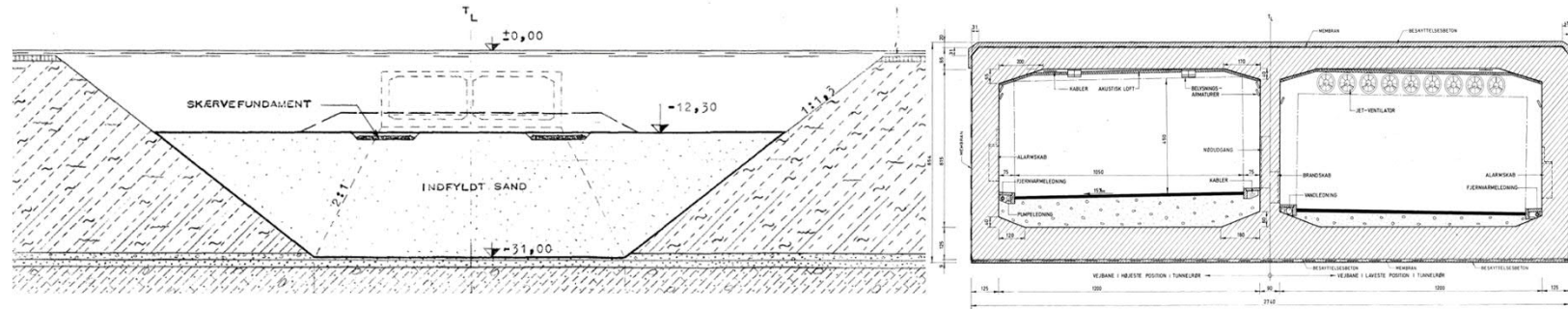

# Drift og vedligehold

## EU Tunnel Directive

# Organizational requirements

## Directive 2004/54

Oversigt (indholdsfortegnelse)

**Bilag I** Betingelse til Europa-Parlamentets og Rådets direktiv 2004/54/EF af 29. april 2004 om minimumssikkerhedskrav for tunneler i det transeuropæiske vejnet

**Bilag II** Sikkerhedsforanstaltninger som omhandlet i artikel 3

**Bilag III** Godkendelse af byggeprojektet, sikkerhedsdokumentation, driftsætning, ændringer og regelmæssige øvelser

**Bilag IV** Skiltning i tunneler

Den fulde tekst

**Bekendtgørelse om minimumssikkerhedskrav for tunneler i det transeuropæiske vejnet<sup>1)</sup>**

I medfør af § 109 i lov om offentlige veje, jf. lovbekendtgørelse nr. 432 af 22. maj 2008, § 66 a i lov om private fællesveje, jf. lovbekendtgørelse nr. 433 af 22. maj 2008 og § 95, stk. 1 og 3 i færdselsloven, jf. lovbekendtgørelse nr. 1276 af 24. oktober 2007, fastsættes efter bemyndigelse:

**§ 1.** Europa-Parlamentets og Rådets direktiv 2004/54/EF af 29. april 2004 om minimumssikkerhedskrav for tunneler i det transeuropæiske vejnet gennemføres ved denne bekendtgørelse i dansk ret

Stk. 2. Direktivet er optaget som bilag til denne bekendtgørelse.

**§ 2.** Vejdirektoratet er administrativ myndighed for tunneler i det transeuropæiske vejnet, jf. direktivets artikel 4, stk. 1. Dog er A/S Øresundforbindelsen administrativ myndighed for Tårnby-tunnelen og Øresundbro Konsortiet I/S administrativ myndighed for Droegden-tunnelen.

Stk. 2. Vejdirektoratet udøver i øvrigt de beføjelser, der i direktivet er tillagt medlemsstatene.

**§ 3.** Afmærkning i tunneler sker efter retningslinjerne i direktivets Bilag III, bortset fra de tilfælde der er nævnt i stk. 2-6.

Stk. 2. Ved tunnelindgængsel opsættes tavle A 44, jf. bekendtgørelse om vejafmærkning.

Stk. 3. Afmærkning på kørebanen udføres i overensstemmelse med bekendtgørelse om vejafmærkning.

Stk. 4. Vigespor afmærkes med tavle E 34 og kan suppleres med undertavle UE 34, jf. bekendtgørelse om vejafmærkning.

Stk. 5. Vognbasesignaler udføres i overensstemmelse med bekendtgørelse om vejafmærkning.

Stk. 6. Anvendelse af variable informationstavler skal i hvert enkelt tilfælde godkendes af Vejdirektoratet.

**§ 4.** Bekendtgørelsen træder i kraft den 9. juli 2008.

Stk. 2. Samtidig ophæves bekendtgørelse nr. 892 af 18. august 2006 om minimumssikkerhedskrav for tunneler, der er offentlig vej, og som indgår i det transeuropæiske vejnet.

**BEK nr 726 af 03/07/2008**  
Gældende  
Offentliggørelsesdato: 09-07-2008  
Transport- og Bygningsministeriet  
[Vis mere...](#)

**Senere ændringer til forskriften**  

- BEK nr 142 af 20/02/2012
- BEK nr 1183 af 23/09/2016

**Lovgivning forskiften vedrører**  

- LDV nr 1520 af 27/12/2014
- LK nr 1226 af 04/11/2015
- LK nr 38 af 05/01/2017

**Ændrer i/ophæver**  

- BEK nr 892 af 18/08/2006

**Links til EU direktiver, jf. note 1**  
[32004L0054](#) [html](#) [note](#) [x](#)

**Yderligere dokumenter:**  

- Forslag, som implementerer EU direktiv 2004/0054
- Alle arkivaler, vejledninger m.v. til denne bekendtgørelse
- Afgører trafik i henhold til denne retsafsnit
- Gørelser fra ombudsmanden, der anvender denne retsafsnit

## The organisation

- ✓ Administrative Authority
- ✓ Tunnel Manager
- ✓ Safety Officer
- ✓ Inspection Unit





Operation and Maintenance

# The Limfjord Tunnel

Safety Officer: Supervising and conducting meetings 3 times per year:

- Emergency Preparedness Meetings (Safety Officer, Police, Rescue Operators, Paramedics, Contractors and Consultants)
- Ad-hoc participating in Meetings with Tunnel Manager, Safety Officer, Contractors and Consultants (only the safety part).

Tunnel Manager: Supervising and conducting Operation Meetings:

- Monthly Operation Meetings (Tunnel Manager, Contractors and Consultants)
- Maintenance strategy: 24/7 on call to the Maintenance Contractor and 3 preventive (routine) inspections per year. Monthly follow-up meetings.



Mechanical & Electrical Auxiliary systems

# The Limfjord Tunnel

- ITS (Intelligent Transport System)
- Video surveillance CCTV
- Automatic Incident Detection system (AID)
- Detection of vehicles with dangerous goods
- Control/alarm of heights of vehicles
- Ventilation
- Lighting systems / solar cells
- Drainage Systems
- Alarm cabinets and emergency doors
- Emergency telephones
- fire alarm / (fire pressure in alarm cabinets and smoke detectors in buildings)
- Fire detection in the tunnel
- Automatic fire extinguishers in the boardroom in the buildings
- Power supply; 2-sided redundant supply
- Emergency supply / diesel generator (UPS) and battery supply
- SCADA system



# 50 års drift og vedligeholdelse

## Operation and Maintenance

# Major repairs during lifetime

- 1993 – 1994: Coating replacement and installation of 60 pieces longitudinal tension cables located in the ballast concrete under coating. This due to extreme consolidation between section IV and V.
- 1995 – 1998: Concrete renovation (extensive) and sealing inside. New tiles on walls.
- 1998 – 1999: Fire protection of tunnel ceilings with an expansion mortar product.
- 2010 – 2011: Repair of tunnel ceilings by drilling stainless steel lining and mounting of clamping anchors and nuts and jointing. Rehabilitation of fire protection.
- 2011- 2012: Special inspection of cracks and leaks. Geotechnical studies.
- 2012: Replacement of ballast concrete and asphalt coating in both tunnel tubes.



## Operation and Maintenance - Limfjord Tunnel



## Operation and Maintenance - Limfjord Tunnel

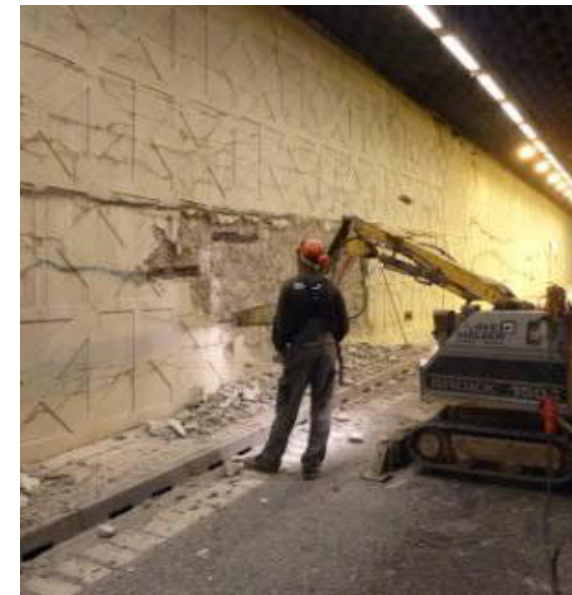

## Waterproofing has been carried out frequently

- The tunnel is waterproofed with an outer rubber membrane under protective concrete and stone casing, but this has been depleted since commissioning.
- From the beginning, cracks and leaks were found in the concrete - especially at the construction joints.
- In the 1970s and 80's many seals and repairs were done and tested different solutions.
- An important task has been carried out in communicating to the public that the tunnel is safe - despite the fact that salt water enters the tunnel.



# Baggrunden for nedsættelse af ekspertgruppen



## Limfjord Tunnel

# Major repairs, costs and settlements

### Major repairs, costs and settlements

- Water-proofing membrane.
- Cracks in the tunnel roof and outer walls.
- Settlements of the tunnel.
- Corrosion of the reinforcement.
- Post-tensioning cables installed in 1993-94.
- Reinforcement and concrete repair late 1990's.
- Anchors repair due to delamination in 2010.

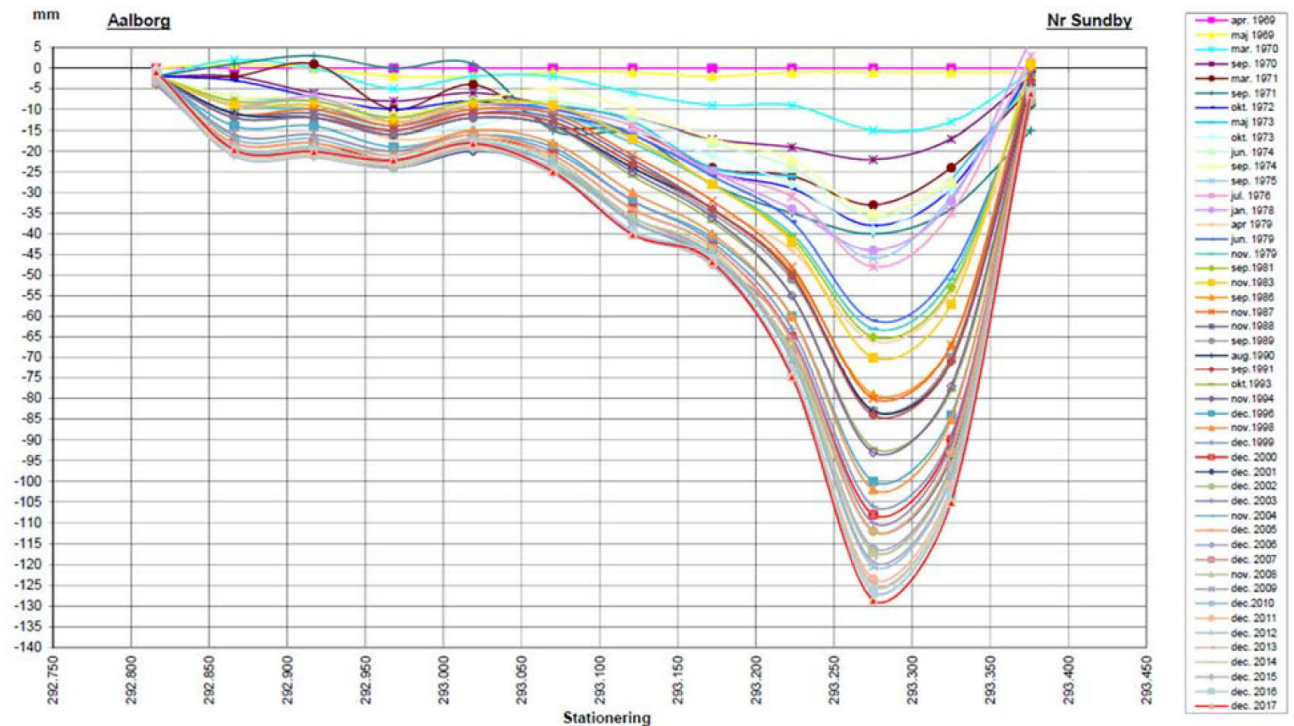

# Accumulated cost for operating and maintenance of Structures, Mechanical & Electrical systems

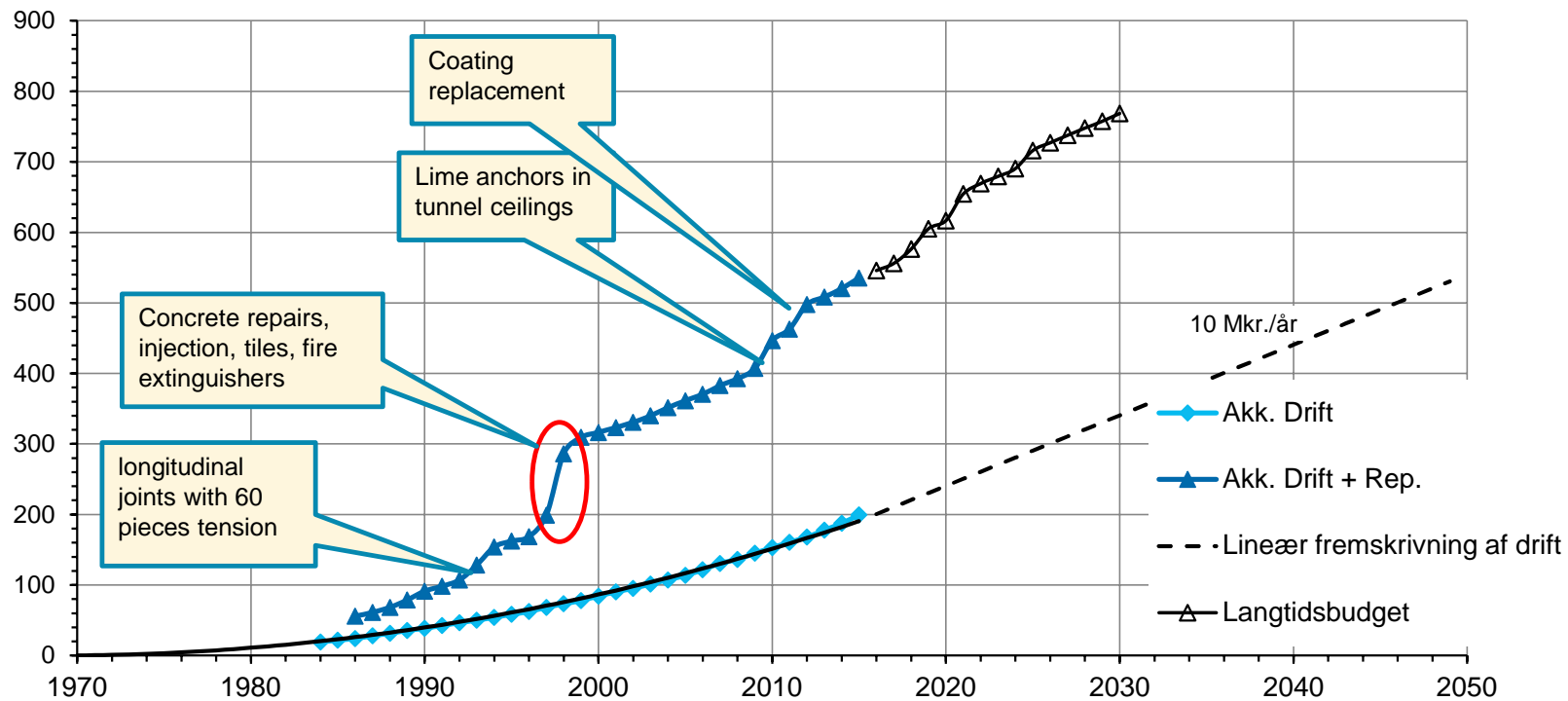

Limfjord Tunnel

# Structural Expert Group 2018-2019

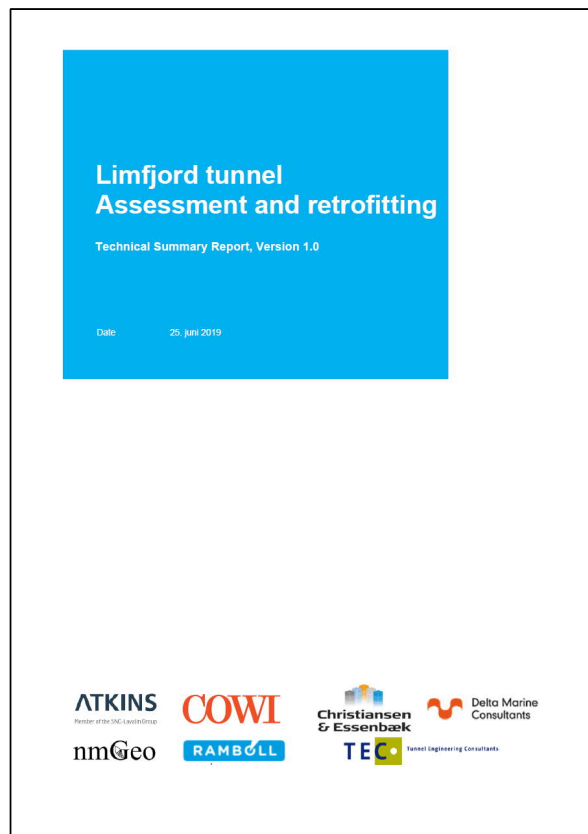

## Drivers

- Leakages and water ingress
- Repair and strengthening works
- Recorded settlements showing no signs of decreasing
- Great attention from local users and politicians
- Accumulated cost for operating and maintenance of Structures

## Objective

The objective of the work carried out by the Structural Expert Group and summarized in this report has been to provide the Danish Road Directorate with suitable and practical guidance to maintain, repair and correct (where relevant) the structures of the Limfjord Tunnel for the remaining lifetime of the tunnel until the year 2069.

# Structural Expert Group 2018-2019

## Expert group:

Carsten Schjørring (Christiansen & Essenbæk)

Hans de Wit (TEC)

Hans Henrik Christensen (Rambøll)

Lars Knud Lundberg (Rambøll)

Michael Gavins (Atkins UK)

Michael Tonnesen (COWI)

Niels Mortensen (nmGeo)

Nhut Quang Nguyen (BAM)

## Other participants:

Dorthe Lund Ravn (COWI)

Finn R. Gottfredsen (COWI)

Peter Møller (Rambøll)

Niels Chr. Skov Nielsen (VD)

Jørn Kristensen (VD)

Anne Louise Schaarup (VD)

Niels Fejer Christiansen (VD)

Niels Højgaard Pedersen (VD)

## Overall time line / Scope of works

**Problem:** The tunnel settles and water keeps leaking inn.

Doubt about the structural safety of the tunnel in the future due to the continued settlements and the continued leakages in certain areas.

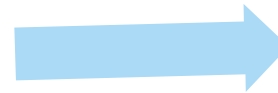

**Geotechnical expert group:**  
Clarify the primary cause of the observed settlements and predict expected settlements for the next 50 years.



**Structural expert group:**  
Establish long-term optimum maintenance plan, including solution(s) for repair project(s). The proposed solution(s) must be assessed in terms of both technology, economy and traffic.



**Verification of the structural safety of the tunnel for the next 50 years.**  
*Propose the necessary retrofitting / mitigation in case of lack of carrying capacity.*

Verify that the condition of the tunnel is satisfactory and that the operation of the tunnel is adequate based on a reasonable maintenance and repair scheme for the next 50 years.

*Propose the necessary retrofitting / mitigation / repair works in case of increasing amount of leakages, corrosion of reinforcement and other types of deterioration. Prepare a long term maintenance and repair strategy.*

Timeline of the expert groups

# Methodology of the expert group(s)

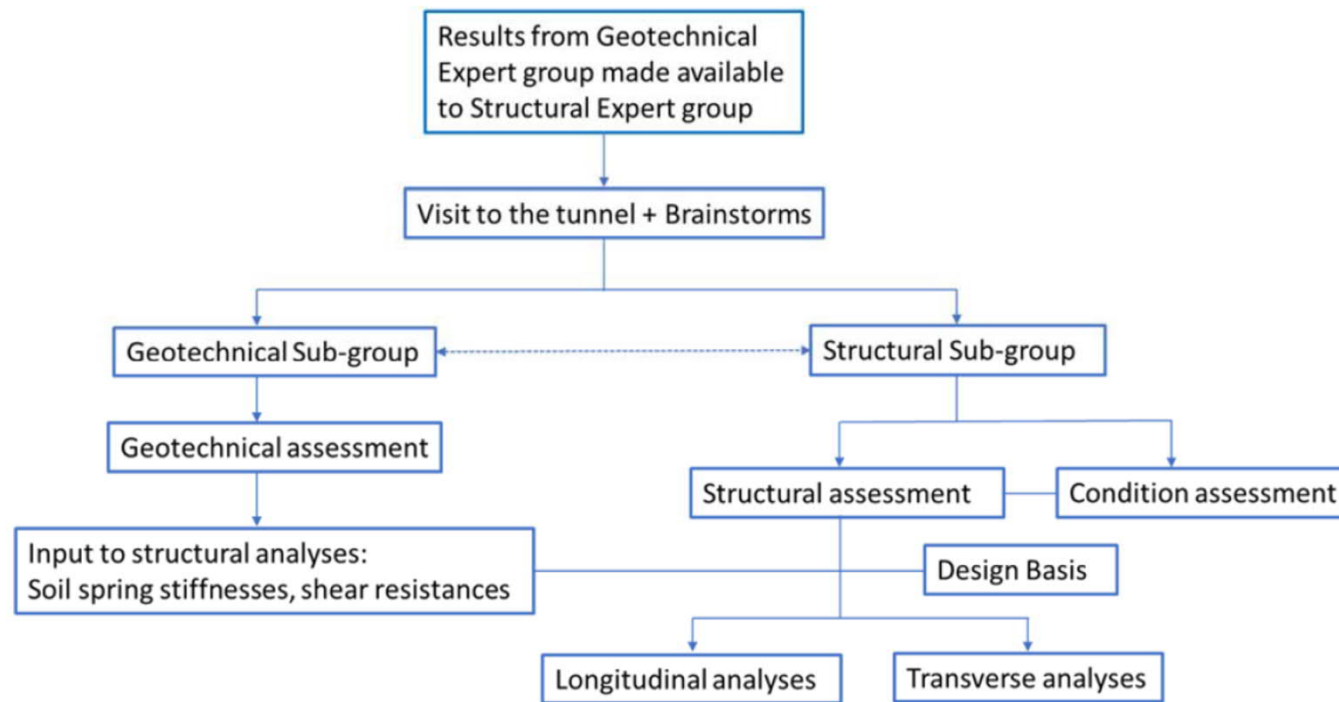

Figure 2.2-1 Work organization flow chart

- The Geotechnical Expert Group acted in the period of May 2017 to April 2018 for identifying the reasons for the observed settlements.
- The Structural Expert Group started their work in May 2018 and concluded their work in June 2019
- Both groups was facilitated from DRD and supported with all necessary information's and data.

# Konklusioner fra den geotekniske gruppe

Defect:

- Large settlement at TE-IV & TE-V

130mm (2017)

190mm (2067) prediction

Cause:

- Creep settlement of Sand Fill (Interaction with Gytja deposits on each side of tunnel cross section)

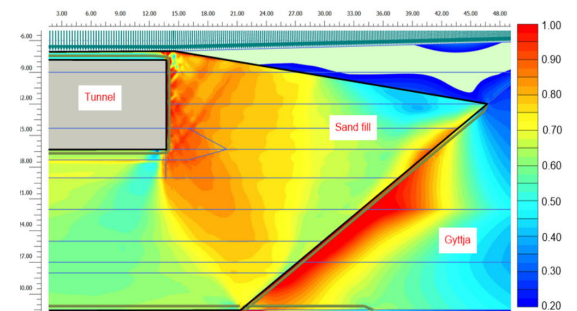
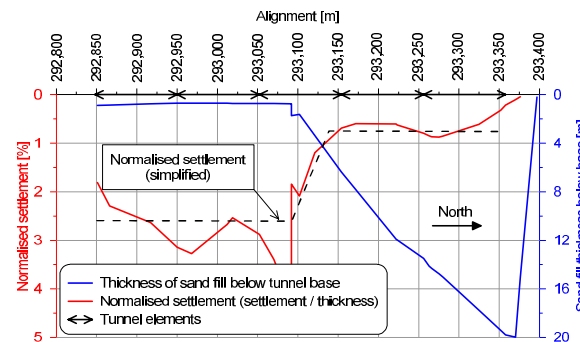
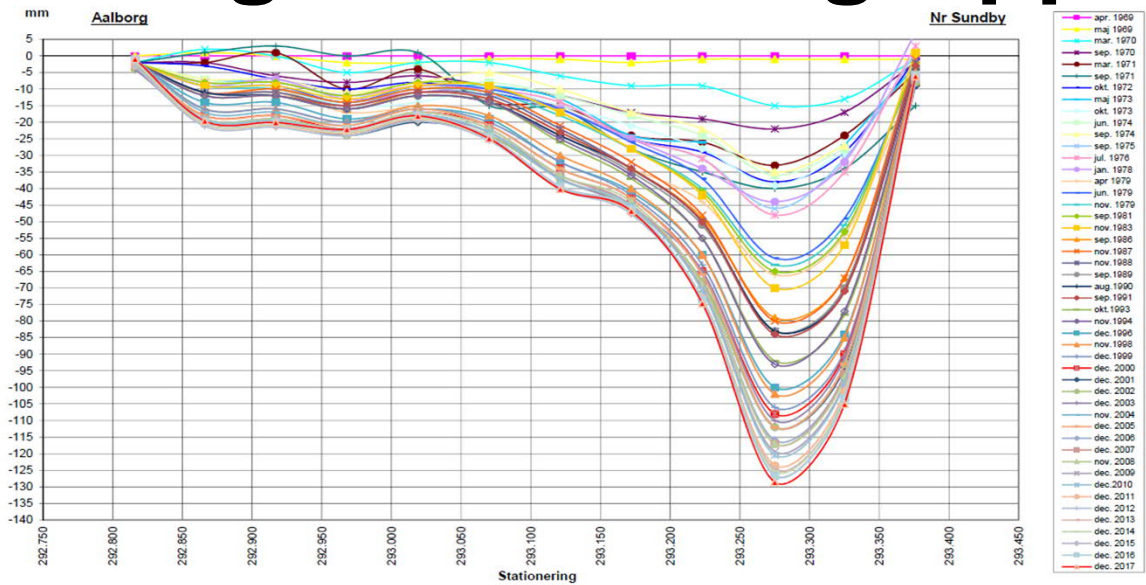

## Condition assessment – Investigations/sampling in situ

- 5 cores from external face of tunnel
  - macro analysis
  - chloride profiles
- Cores from inside tunnel (walls and roof)
  - 51 cores (macro analysis)
  - 43 for compression testing
  - chloride profiles
  - thin sections
- Non-destructive testing
  - HCP-measurements (to assess risk of corrosion)
  - Pundit (=ultrasonic pulse velocity and pulse echo testing)
  - Georadar (to locate rebars)
- 3 cores from bottom slab
  - macro analysis
  - micro analysis (4 thin sections)





# Condition assessment - Concrete

- Compression tests

Number of cores - compression testing

Section	Element		
	II	III	V
Long sections, Top slab (LSL)	4	6	6
Long sections, Walls (LSV)	5	5	5
Short sections (KSL+KSV)	4	4	4

Mean compressive strength

Section	Element		
	II	III	V
Long sections, Top slab (LSL)	60,8	63,3	64,3
Long sections, Walls (LSV)	51,3	62,8	57,7
Short sections (KSL+KSV)	58,1	68,4	60,8

Group	Characteristic In-situ compressive strength [MPa]		
	Unknown coefficient of variation	Known coefficient of variation	
		-	0,18
Element II - Long section - Top slab	52,6	43,7	47,9
Element II - Long section - Walls	31,3	36,5	39,9
Element II - Short section	43,2	41,6	45,6
Element III - Long section - Top slab	49,5	45,8	50,0
Element III - Long section - Walls	50,8	45,2	49,5
Element III - Short section	47,0	48,8	53,5
Element V - Long section - Top slab	49,7	46,5	50,8
Element V - Long section - Walls	44,1	41,5	45,4
Element V - Short section	48,1	43,6	47,8
All cores grouped	47,7	44,7	48,6

- Water content – see next slide

- Chloride content – varies very

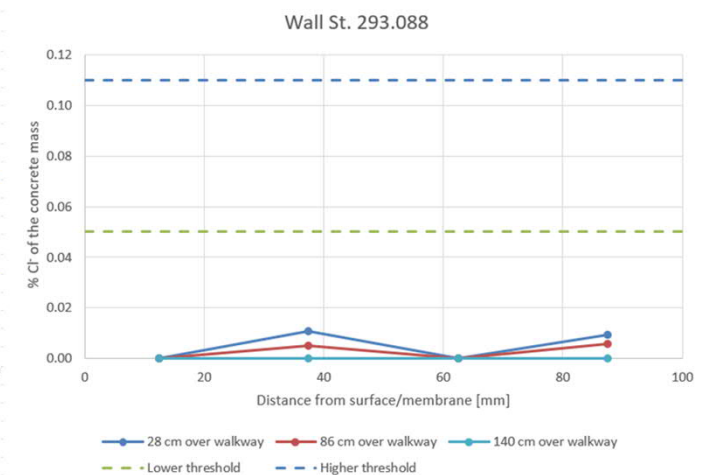
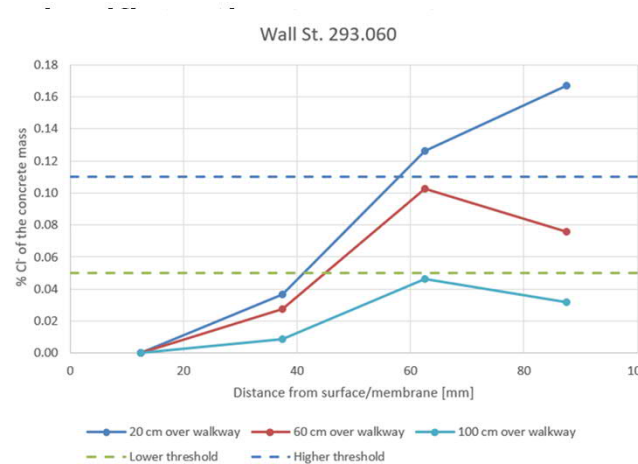
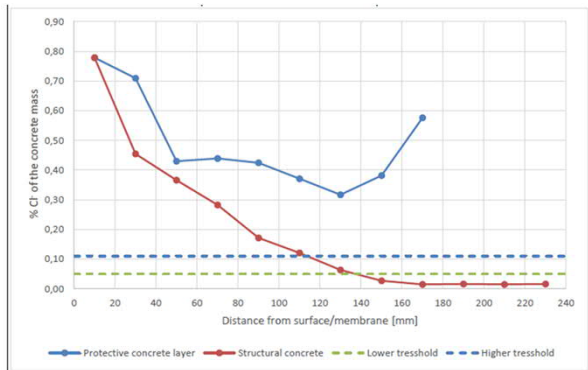

# Structural assessment, Longitudinal direction - model



Geometric Key  
Analysis: Analysis 1

- Walls
- Top plate\_Area B (Top plate B major z)
- Top plate\_Area A (Top plate A major z)
- Bottom plate (Bottom plate major z)

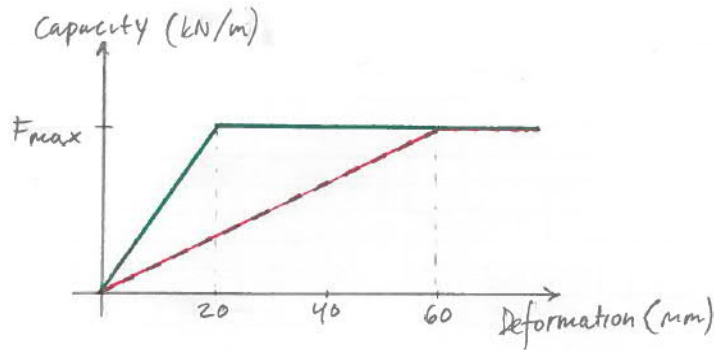
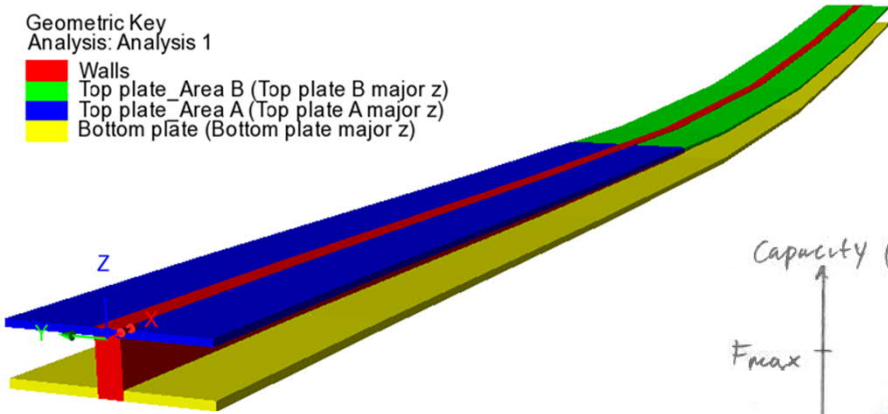

E-modulus, compression: 17.000 MPa

E-modulus, tension: 8.000 MPa

Concrete properties

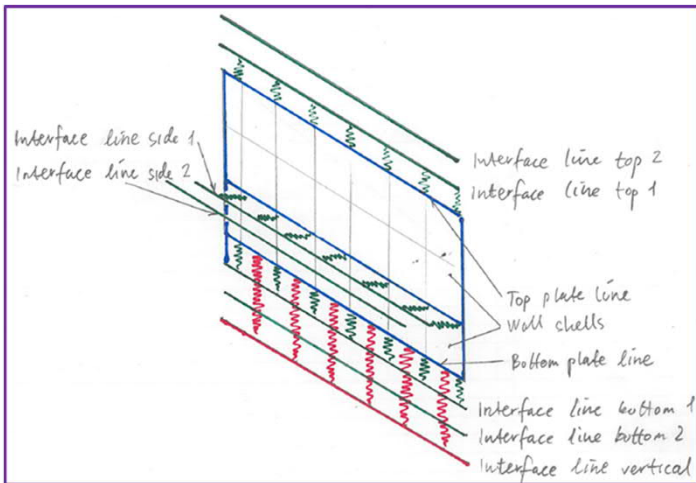
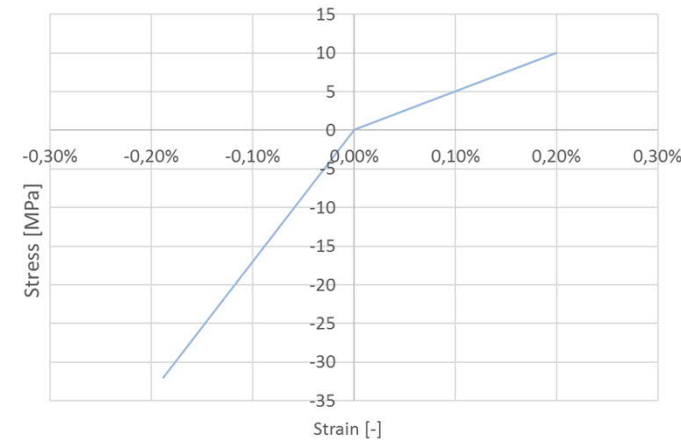

Longitudinal soil-structure interaction  
Shear capacity as function of the deformation  
Full regeneration of shear capacities is assumed

# Ekspertgruppens konklusioner

- Den overordnede tilstand af tunnelen er bedre end forventet. Der er således ikke fundet korrosion af betydning i armeringsjernene, og betonens styrke og kvalitet er tilstrækkelig til at optage de kræfter, der påvirker konstruktionen.
- De i 1990'erne og 2000'erne gennemførte reparationsprojekter – opspænding med kabler i ballastbetonen, omfattende betonreparationer, iboring af rustfrie limankre i tunnellofter mv - har haft en god og positiv virkning på konstruktionen.
- Revnerne i tunnelen skyldes primært sætninger i tunnelens nordlige halvdel, samt årlige temperaturvariationer, der udsætter betonen for skiftende træk og tryk. Disse påvirkninger vil fortsætte således, at der fortsat udvikles revner, samt at der fortsat vil opstå utætheder i betonen.
- Ekspertgruppen forventer ikke, at det bliver nødvendigt at gennemføre større reparationsprojekter inden for de næste 10 – 15 år, forudsat at udviklingen på de væsentligste parametre fortsætter som forventet.

# Ekspertgruppens konklusioner

- Der anbefales derfor en yderligere overvågning og monitorering ud over det, Vejdirektoratet allerede nu gennemfører. Det drejer sig bl.a. om måling af bærende kræfter ved det nordlige endevederlag, årligt eftersyn af kritiske samlinger i betonen i vægge og lofter, kontinuerlige målinger af armeringskorrosion og vandindhold, måling af kloridindhold hvert 5. år, samt gennemførelse af diverse tests af betonen hvert 10. år.
- Såfremt der mod forventning viser sig udbredt korrosion, kan det overvejes at gennemføre katodisk beskyttelse i delområder af tunnelen, hvilket dog ikke forventes aktuelt inden for de første 10 år.
- Alle de nuværende målinger så som sætningsmålinger, målinger af længdebevægelser mv. skal fortsætte, og ligeledes bør der fortsat gennemføres årlige injiceringer (tætninger) af revner i betonen for at begrænse vandindtrængning..

## 3 større reparationsprojekter

- Derudover har ekspertgruppen foreslået 3 større reparationsprojekter til evt. udførelse om 15 – 50 år, såfremt behovet måtte være til stede.
- Det drejer sig dels om at etablere yderligere opspænding, der placeres på den øverste del af tunnelvæggene – samme princip som blev gennemført i 1993 i ballastbetonen, dels en sænkning af det nordlige leje. Begge foranstaltninger vil medføre færre revnedannelser, og dermed mindre behov for injiceringer af betonen, der dermed vil få en længere levetid. De pågældende tiltag vil kræve, at der lukkes for trafikken i et tunnelrør af gangen i flere uger, og vil dermed forårsage store trafikale gener.
- Derudover foreslår ekspertgruppen at gennemføre løft af den nordlige del af tunnelen, såfremt de fremtidige sætninger skulle blive større end forventet. Dermed kan man ligeledes minimere spændingerne og revne-dannelsen.

## The Limfjord Tunnel

# Retrofitting Projects

1. Additional prestressing (year 2035)
2. Replace bearing blocks (year 2045)
3. Active horizontal compensation grouting (year 2064)

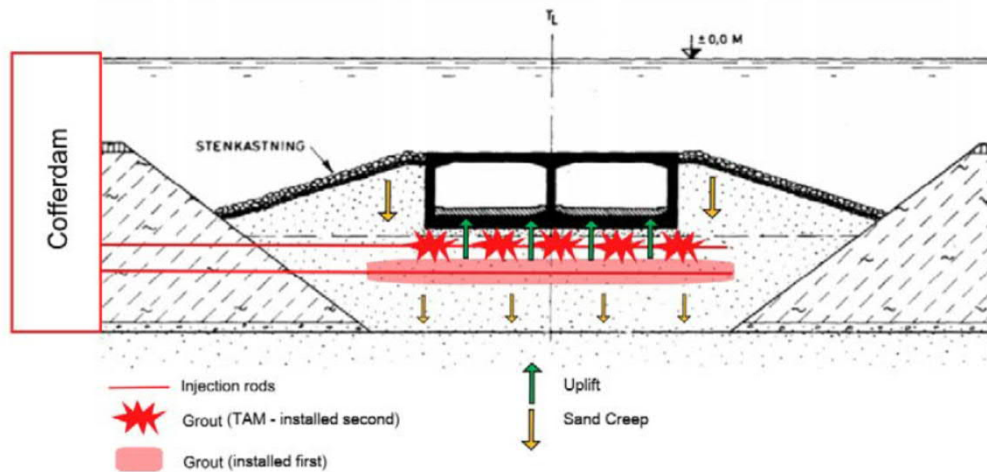

Figure 9.2-3 Section showing indicative pre-treatment and compensation grout injection tubes.

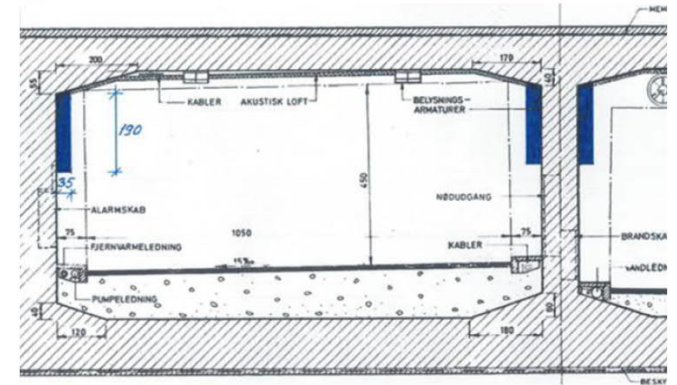

Figure 9.3-1 Spaces available for installations such as external post tensioning cables (blue colour) along upper part of all wall surfaces.



4.1-3 Elastomeric bearing at the northern portal building.

# The Limfjord Tunnel – 50 years budget

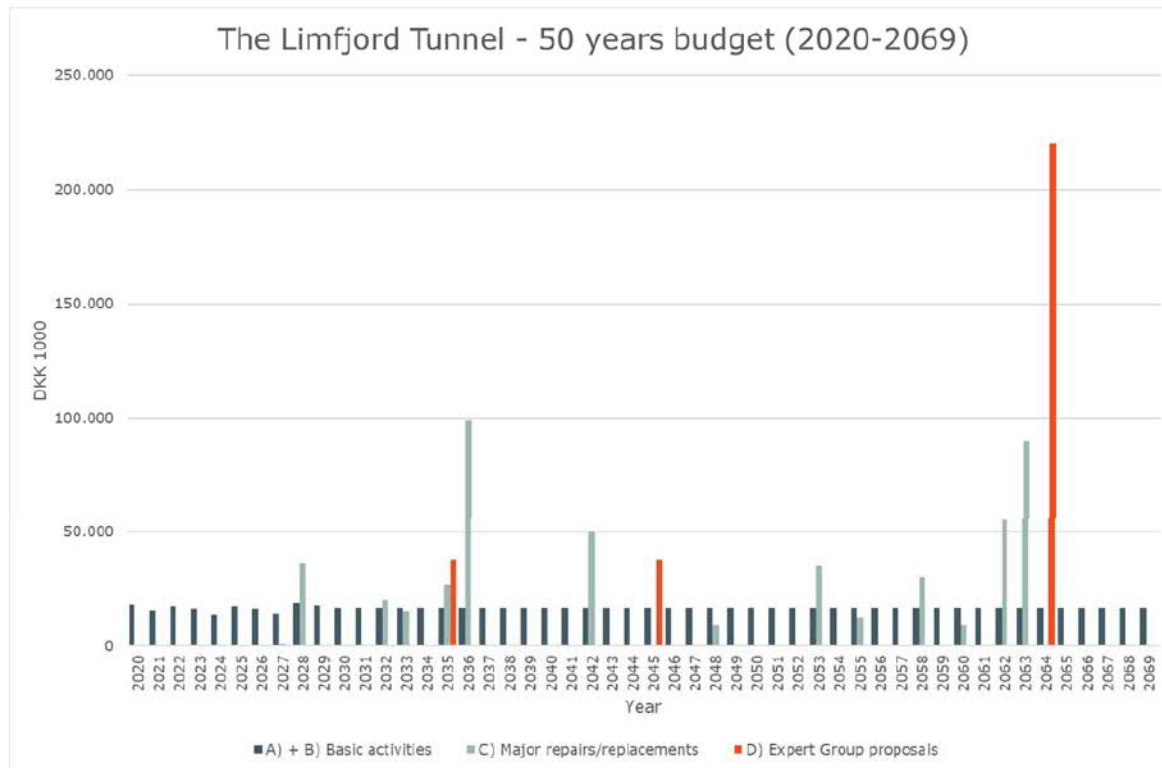

Figure 10.3-1 50 years budget for the Limfjord Tunnel based on current 10 years budget supplemented with activities recommended by the Structural Expert Group.

## Costs

- A) Basic Operation & Maintenance
- B) Supplementary Inspection, Monitoring and Maintenance
- C) Major repairs/replacements
- D) Experts Group Proposals - Retrofitting

# Konsekvenser af ekspertgruppens konklusioner

- Vejdirektoratets nuværende 10 årsbudget for drift- og vedligehold af Limfjordstunnelen udgør ca. 11,5 mio. kr. årligt. Såfremt Vejdirektoratet skal gennemføre den af ekspertgruppen supplerende overvågning og monitorering, samt mindre løbende vedligeholdsarbejder, så som reparation af brandsikring i lofterne, mindre øvrige betonreparationer, ny fuge i den sydlige ende af tunnelen og lign. vil dette betyde i gennemsnit at 10-årsbudgettet ville blive på ca. 16,5 mio. kr. årligt, altså en gennemsnitlig forøgelse på ca. 5 mio. kr. årligt.
- Gennemførelse af de 3 foreslåede større reparationsprojekter vil beløbe sig til følgende:
  1. Yderligere opspænding: ca. 35 – 40 mio. kr.
  2. Sænkning af nordlig leje: ca. 35 – 40 mio. kr.
  3. Løftning af den nordlige del af tunnelen: ca. 200 – 240 mio.kr.



# Andre anbefalinger

## Klimavurderinger

- Klimasikring af Limfjordstunnelen Baggrund COWI har som driftsrådgiver for Vejdirektoratet i 2020 udført følgende klimavurderinger af Limfjordstunnelen:
- Stormflod
- Skybrud
- Grundvand
- Baggrunden herfor er bl.a vurderinger og anbefalinger udført af en ekstern ekspertgruppe nedsat af Vejdirektoratet, som generelt har vurderet Limfjordstunnelens tilstand, jf. rapporten: "The Danish Road Directorate. The Limfjord tunnel, basic maintenance and repair strategy, COWI juni 2019".

## Sikkerhed mod skibsstød

- Preliminary ship accident risk analysis
  - Sunken Ship (ok)
  - Grounding Ship
  - Dropped Anchor (ok)
  - Dragged Anchor (ok)
- Recommend: Detailed evaluation of possible protective structure and load from a grounding ship on TE-V



Tak for opmærksomheden